

# Toward a Sustainable Impeller Production

## Environmental Impact Comparison of Different Impeller Manufacturing Methods

Shitong Peng,<sup>1</sup> Tao Li,<sup>1</sup> Xinlin Wang,<sup>1</sup> Mengmeng Dong,<sup>1</sup> Zhichao Liu,<sup>2</sup> Junli Shi,<sup>1</sup> and Hongchao Zhang<sup>1,2</sup>

<sup>1</sup>School of Mechanical Engineering, Dalian University of Technology, Dalian, China

<sup>2</sup>Department of Industrial Engineering, Texas Tech University, Lubbock, TX, USA

### Keywords:

additive manufacturing  
conventional manufacturing  
environmental impact  
impeller  
life cycle assessment  
remanufacturing

 Supporting information is linked to this article on the JIE website

### Summary

Impellers are the core components of turbomachinery in petrochemical and aeronautical engineering. In addition to conventional manufacturing (CM), additive manufacturing (AM) and remanufacturing (RM) can also be used in impeller production. This article presents a life cycle assessment method comparing the environmental impacts of different impeller manufacturing methods, including plunge milling (CM), laser cladding forming (AM combined with CM), and additive remanufacturing (RM). Results show that RM is the most environmentally favorable option, followed by AM and CM, in terms of global warming potential (GWP), Chinese resource depletion potential (CADP), water eutrophication potential (EP), and acidification potential. However, AM is not always more environmentally friendly than CM. The comparison of impeller production by CM and pure AM, in this case, indicates that the environmental burden of production using pure AM is approximately twice that of CM. Compared with CM, the RM of impellers would reduce GWP, CADP, and EP by 64.7%, 66.1%, and 75.4%, respectively. The results of this study contribute to a scientific basis for the selection of manufacturing methods and the sustainable manufacturing of impeller production enterprises.

### Introduction

The manufacturing industry consumes the largest amount of energy and accounts for a substantial share of 38% for global carbon dioxide (CO<sub>2</sub>) emission (Zhu et al. 2015). According to the International Energy Agency (IEA), China, a major global economy, is the largest CO<sub>2</sub> emitter around the world. China contributes 28% to global CO<sub>2</sub> emission (IEA 2015). Given the country's rapid economy development, the manufacturing sector of China directly or indirectly consumes over 50% fossil fuel in electricity utilization and heat generation (Yan and

Fang 2015). Therefore, mitigating energy-related emissions will benefit China and the whole world considering such a level of consumption. Energy shortage, resource depletion, and environment deterioration are inevitable obstacles that hinder manufacturing activities. Many rigorous policies have been implemented to compulsorily constrain the atmospheric emissions, effluents, and solid wastes. Cleaner production and circular economy development are highly advocated to reduce pollution from sources (NDRC and SEPA 2007). The increase of public environmental consciousness, legal pressure, and market

**Conflict of interest statement:** The authors have no conflict of interest to declare.

**Address correspondence to:** Tao Li, Institute of Sustainable Design and Manufacturing, Dalian University of Technology, No. 2 Linggong Road, Ganjingzi District, Dalian City 116024, Liaoning Province, China. Email: lt\_dlut@163.com

© 2017 The Authors. *Journal of Industrial Ecology*, published by Wiley Periodicals, Inc., on behalf of Yale University. This is an open access article under the terms of the Creative Commons Attribution License, which permits use, distribution and reproduction in any medium, provided the original work is properly cited.  
DOI: 10.1111/jiec.12628

Editor managing review: Martin Baumers

competition push manufacturers to seek sustainable development. Managers and engineers should consider all the three aspects: economic, social, and environmental impacts (Zhang and Haapala 2015).

Many innovative technologies emerged in the impeller manufacturing industry. These technologies aimed to advance sustainable manufacturing. The impeller is a typical difficult-to-machine component with twisted and thin blades. The design level and manufacturing quality of the impeller are decisive factors that influence the operation of the entire equipment. Current mainstream impellers production is still CM and has been studied by many researchers (Chuang and Young 2007; Han et al. 2015; Young and Chuang 2003). At present, AM is also applied to impeller production (Calleja et al. 2014; Fernández et al. 2015). Impeller RM has received extensive attention as well (Bi and Gasser 2011; Wilson et al. 2014). As defined by the American Society for Testing and Materials, AM is “a process of joining materials to make objects from 3D model data, usually layer upon layer, as opposed to subtractive manufacturing methodologies” (Frazier 2014, p. 1917). The process has significant potential for improving the efficiency of materials and reducing environmental impact (Huang et al. 2015). The comparison of environmental impact between the CM process and the AM process has been explored by many researchers. A framework for the evaluation of environmental impact was proposed to guide commercial vehicle manufacturers in predicting environmental loads (Burkhart and Aurich 2015). In order to further develop a design for sustainable additive manufacturing, an environmental impact predictive model had been established (Le Bourhis et al. 2014). Serres and his coauthors conducted an environmental comparison of direct additive laser manufacturing and conventional machining through life cycle assessment (LCA); they concluded that the additive laser manufacturing was time-intensive, but it reduced resource consumption and human health damage by approximately 70% (Serres et al. 2011). Huang and colleagues estimated the primary energy demand and the greenhouse gas emission (GHG) of AM for lightweight aircraft components; they identified the environmental benefits provided by shifting the manufacturing model from CM to AM. This shift showed that most of the energy conservation stems from much less fuel consumption during usage due to the lighter weight of AM parts, especially the furnishings and equipment system components. AM also demonstrates energy and material saving in other areas beyond airplane parts (Huang et al. 2015).

AM could consume more energy than CM when manufacturing the same components (Huang et al. 2013). The specific energy consumption (SEC) of AM is higher than that of traditional bulk forming process by approximately 100 times and is also higher than that of conventional subtractive processes (Yoon et al. 2014). The comparison of environmental impact between AM and CM changes significantly with different types of components (Rajemi et al. 2010; Serres et al. 2011). This study explores the following questions. Is the superiority of AM, also called “the third industrial revolution,” overemphasized from the perspective of environment? What are the influence

factors of environmental loads on AM? Those questions remain unanswered.

Only a few reviews on comprehensive environmental impact have compared the impellers manufactured by AM, CM, and corresponding RM methods. To overcome this research gap, the present study established an LCA model of different impeller production methods and compared their environmental impacts. The assessed production methods include CM via plunge milling, an AM route combining a blown powder deposition process with machining, and RM. A pathway in which the entire impeller is manufactured with AM, referred to in this paper as “pure AM,” is also considered. The impeller under study is manufactured with titanium alloy material and its three-dimensional (3D) model is presented in figure 1. Results of this article will offer guidance to the designers and engineers to integrate the environmental dimension into the initial impeller design phase and the manufacturing operation scheduling. It will also provide a scientific basis for selection of impeller manufacturing methods and potential improvement of environmental performance of AM, RM, and CM.

This article is divided into five sections. Following this introduction, the next section illustrates technical backgrounds on three manufacturing methods (AM, CM, and RM; general procedures are presented in figure S2 in the supporting information available on the Journal’s website) as well as relevant data on impeller manufacturing. In the section following, the LCA methodology is applied to determine the environmental impacts and make comparisons. In the next section, the environmental impacts of pure AM and CM are compared. The conclusions and perspectives are summarized in the final section.

## Impeller Manufacturing Methods and Data

### Conventional Impeller Manufacturing

The CM method is still the mainstream for impeller production in order to guarantee quality. CM generally refers to the machining processes in a subtractive way. Before machining, casting and forging are exploited to obtain the workblank. Then conventional manufacturing technologies, such as turning, milling, planing, drilling, and grinding, are utilized to remove the extra metallic layers until reaching the form and position precision by a series of rough and finish machining processes. The metal removal processes can be implemented through mechanical force like the cutters exerted on the workblank and nonmechanical force such as the optics and electricity in the laser machining and electrosparking, respectively. Titanium alloy impeller has wide industrial applications due to its high strength and corrosive resistance. But the titanium alloy is recognized as difficult-to-machine material because of its high chemical activity and low thermal conductivity. On account of the material removal efficiency and suitability for complex surface machining, plunge milling is often selected for

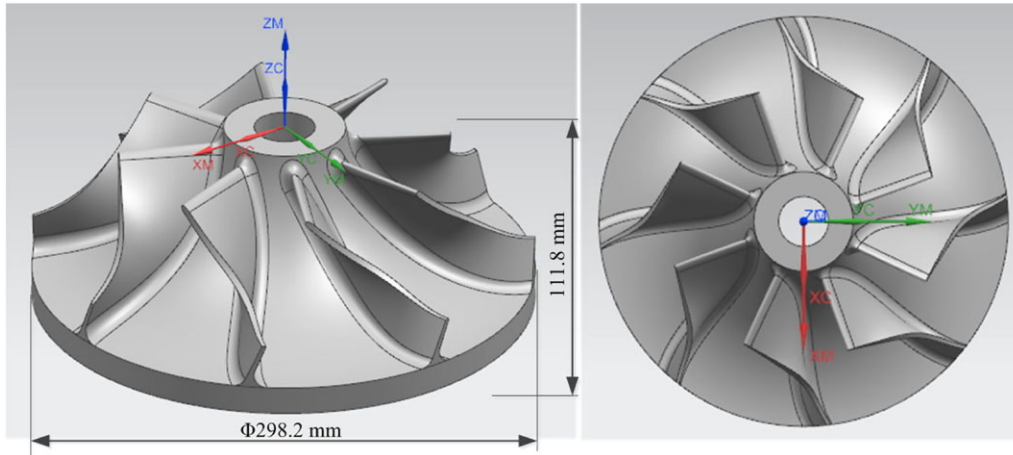

**Figure 1** Impeller selected for this study. mm = millimeters.

the rough machining of impellers (Han et al. 2014). Utilizing the computer numerical control (CNC) machining center and dynamometry system, Ren and colleagues conducted a research on plunge milling process for titanium alloy and established the empirical model of cutting force calculation based on an orthogonal experiment with three factors and four levels (Ren et al. 2010). Plunge milling process comprises four essential elements: milling speed ( $v_c$ ); feed ( $f_z$ ); cutting depth ( $a_p$ ); and cutting width ( $w$ ). The materials removal rate of the plunge milling process is determined by the formula below (equation 1):

$$Q = \frac{a_p \times w \times v_c \times z \times f_z}{\pi \times D} \quad (1)$$

where  $Q$ : removal rate of matter (cubic millimeters per minute [ $\text{mm}^3/\text{min}$ ])

- $v_c$ : milling speed (millimeters per minute [ $\text{mm}/\text{min}$ ])
- $a_p$ : axial cutting depth (mm)
- $w$ : radial cutting width (mm)
- $f_z$ : feed engagement (millimeters per cutter teeth [ $\text{mm}/z$ ])
- $z$ : amount of cutter teeth
- $D$ : diameter of the cutter (mm)

Given the constraints, such as cutting temperature and allowable deflection of cutter cited from the report of Ren and colleagues (2010), the related value of milling parameters are summarized in table 1. In finish milling, finishing allowance is 0.5 mm for the integral impeller based on analytic computing (Zeng 2012). The material removal rate of rough milling and finish milling are determined as 13.9 cubic centimeters per minute ( $\text{cm}^3/\text{min}$ ) and 1.6  $\text{cm}^3/\text{min}$ , respectively, according to equation (1). Volumes of impeller during the plunge milling process are obtained through the computer-aided manufacturing (CAD) model. The machining time during the relative procedure is calculated by dividing the volume difference of adjacent milling stages by material removal rate. The volume variations during the plunge milling processes are presented in table 1.

In order to calculate the energy consumed in the milling process, it requires the milling velocity in three directions and their relevant cutting force. The empirical model of cutting force is established according to principles of metal cutting and curve fitting of experimental data. Cutting forces of plunge milling for titanium alloy in three dimensions are illustrated in equation (2) (Ren et al. 2010). Then, the plunge milling power is determined through the aggregation of each directional cutting force multiplying corresponding milling velocity in its orientation. Since the cutting depth is constant for a single process, the milling velocity in this direction is zero. In addition, the feed rate is quite small compared with milling speed. Nearly all the energy consumption is caused by rotation movement that is the milling speed  $v_c$  (Liu et al. 2015). Consequently, only  $v_c$  and principal cutting force ( $F_x$ ) are considered in the present study to calculate the power consumption as indicated by equation (3).

$$\begin{cases} F_x = 986.28a_p^{0.861} f_z^{0.602} v_c^{-0.073} \\ F_y = 539.51a_p^{0.595} f_z^{0.528} v_c^{-0.012} \\ F_z = 306.90a_p^{1.039} f_z^{0.231} v_c^{-0.045} \end{cases} \quad (2)$$

$$P = \frac{F_x \times v_c}{\eta} \quad (3)$$

where,  $F_x$ ,  $F_y$ , and  $F_z$  are principal cutting force, back force, and feed force; these cutting forces belong to the direction of  $v_c$ ,  $a_p$ , and  $w$ , respectively.  $P$  is the power of the plunge milling (cutting unit), and  $\eta$  is the energy efficiency of cutting unit, which generally ranges from 0.5 to 0.9 and it is fixed at 0.7 in the present study. It also has to be noted that  $P$  in equation (3) is consumed by metal milling alone and accounting for only 10% to 30% of total power of CNC (Li et al. 2014); specifically, the ratio of energy consumption of cutting unit to that of the whole CNC machining center is fixed at 10% in the energy calculation for conservative estimation.

Another important input of milling system beside electricity is the cooling/lubrication fluid (CLF). The majority of CLFs are

**Table 1** Data summary related to conventional manufacturing

Categories	Parameters	Values
Machining parameters	Milling speed $v_c$	113.1 m/min
	Axial cutting depth $a_p$	4.3 mm
	Radical cutting width $w$	10 mm
	Feed engagement $f_z$	0.09 mm/z
	Amount of cutter teeth $z$	2
	Diameter of the cutter $D$	$\Phi 20$ mm
	Material removal rate $Q$	13,932.3 mm <sup>3</sup> /min
Volumes during milling	Volume of workblank	8,677.9 cm <sup>3</sup>
	Volume after rough milling	2,858.0 cm <sup>3</sup>
	Volume of final impeller	2,726.6 cm <sup>3</sup>
	Removal amount of rough milling	5,819.9 cm <sup>3</sup>
	Removal amount of finish milling	131.4 cm <sup>3</sup>
CLF (Pusavec et al. 2010)	Flow rate	4 L/min
	CLF usage	1,000 L/annual
	Machining hour per year	2,112 h/annual
CLF composition (Pusavec et al. 2010)	Oil	20%
	Anionic surfactant	9%
	Nonionic surfactant	11%
	Water	60%
Transportation distance to workshop	Remelting site	18 km
	CLF supplier	40 km
	Workblank supplier	300 km
Machining energy	Power of rough milling	14.46 kWh
	Power of finish milling	2.27 kWh
	Time of rough milling	6.96 h
	Time of finish milling	59.87 h
	Total consumed energy	236.55 kWh

Note: CLF = cooling/lubrication fluid; m/min = meters per minute; mm = millimeters; mm/z = millimeters per cutter teeth; mm<sup>3</sup> = cubic millimeters; cm<sup>3</sup> = cubic centimeters; L/min = liters per minute; h = hours; km = kilometers; kWh = kilowatt-hours.

produced from unsustainable crude oil extraction and often recognized as not biodegradable. CLFs generally contain toxic additives and may severely damage the soil and water sources if handled inappropriately (Pusavec et al. 2010; Debnath et al. 2014; Zhang et al. 2012). Both storage and disposal of CLFs are hazardous and special chemical or physical treatments should be conducted to eliminate the toxic elements inside (Debnath et al. 2014; Jiang et al. 2015). The CLF recycling system in CNC is motivated by a 500-watt pump providing 0.2 megapascals of pressure and flow rate of CLF in the range of 0 to 8 liters per minute (L/min). Compositions of oil-based CLF is presented in table 1.

The workblank of the impeller is a casting part. And consumed energy in casting process is estimated by multiplying the SEC with the mass of workblank. As the International Reference Life Cycle Data System (ILCD) handbook suggests using information from similar processes or regions with similar process operation or older data under the condition of data gaps (IES 2010), SEC of H13 tool steel casting, 1.87 megajoules per kilogram (MJ/kg) (Morrow et al. 2007), can be used to replace that of titanium alloy since the difficulty of data

collection. The melting point of titanium alloy is generally lower than that of pure titanium (about 1,670°C). Given that H13 (4Cr5MoSiV1) has a high melting point of 1,350 to 1,500°C (Chen 1994), the SEC of H13 tool steel and titanium alloy can be similar considering the detailed elements and different foundry equipment. All the chips removed from the workblank in the milling process are transported to nearby iron and steel plants for remelting. And the distance between workshop and iron and steel plant is 18 kilometers (km) measured through an electronic map. We assume the raw materials are transported from Anshan Iron and Steel Group Corporation, the largest iron and steel company in northeastern China, which is 300 km from the workshop.

### Additive Manufacturing for Impellers

Unlike the subtractive manufacturing method, AM is featured with building up components by joining materials layer and layer (Frazier 2014). It does not require conventional cutting tools, fixtures, and multiple machining processes and enables efficient manufacturing for complex shaped components.

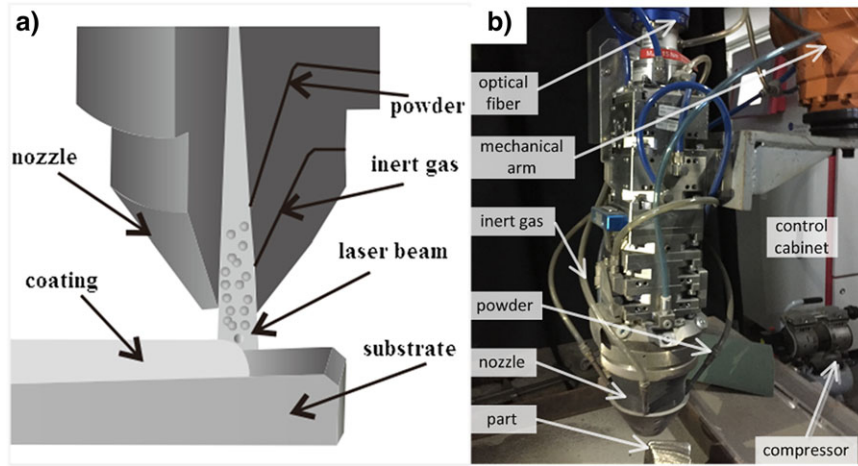

**Figure 2** (a) Schematic diagram indicating the laser cladding process. (b) Constitution of laser cladding forming.

This characteristic enables AM to greatly alleviate manufacturing constraints and significantly broaden the design freedom (Yang and Zhao 2015). According to the material consumed, AM can be classified into three types: liquid based, solid based, and powder based (Wong and Hernandez 2012). In the present study, impeller was manufactured by laser cladding forming, which belongs to directed energy deposition (DED) processes. DED focuses energy into a narrow region to melt material, which is deposited into the melting pool of substrate (Gibson et al. 2015). In light of laser cladding forming, the metallic powders are projected into the laser beam and subsequently fused and deposited onto the substrates to reach metallurgical bonding between contiguous layers. The substrates can be either a flat plate or shaped part on which new additional geometries are fabricated. In this process, a deposition head, typically an integrated combination of inert gas tube, sensors, and powder nozzle, is utilized to deposit materials. A schematic diagram of investigated AM is presented in figure 2a to indicate the deposition process. The constitution of the laser cladding forming is shown in figure 2b. Laser cladding forming enables near-net-shape production so that the shape and size of initial parts are close to the final net component to avoid rough machining. The majority of chips during the entire impeller production process are produced in the rough milling process. The laser cladding system is comprised of six primary units: laser device; mechanical arm; water-cooling machine; compressor; control cabinet; and powder feeder. Their energy- and materials-related parameters are tabulated in table 2. It can be seen that the water-cooling machine and control cabinet are the main contributors to the energy consumption of AM system. The velocity of nozzle is 6 mm per second (mm/s) when melting the powder while 50 mm/s when not melting. The dimension of one deposition layer is 4 mm wide and 0.3 mm high. If the height per layer is too thick, it would influence the bonding strength between layers. Conversely, if the layer is too thin, it would be energy-intensive and time-consuming to complete the work. After cladding one layer, the nozzle will move to the starting point to begin another layer, which would ensure sufficient cooling of the cladding

**Table 2** Data summary related to additive manufacturing

Categories	Parameters	Values
Laser cladding system	Rated power of laser device	1 kW
	Rated power of mechanical arm	3.2 kW
	Rated power of water-cooling machine	6 kW
	Rated power of compressor	0.52 kW
	Rated power of control cabinet	7.8 kW
	Rated power of powder feeder	0.09 kW
	Powder feed rate	0.133 g/s
	Utilization ratio of powder	70% to 80%
Powder production (Serres et al. 2011)	Flow rate of argon	10 L/min
	Efficiency	92.5%
	Time for per kg	3.6 min
Blades of impeller	Gas flow rate	3 m <sup>3</sup> /h
	Volume of a blade	12.7 cm <sup>3</sup>
Transportation to laboratory	Amount of blades	8
	Workblank supplier	300 km
	Metal powder supplier	12 km
Energy consumption	Argon supplier	11 km
	Blades manufacturing	39.7 kWh
	Substrate casting	6.1 kWh
	Powder production	0.6 kWh
	Aftertreatment	31 kWh

Note: kg = kilograms; kW = kilowatts; g/s = grams per second; L/min = liters per minute; min = minutes; m<sup>3</sup>/h = cubic meters per hour; cm<sup>3</sup> = cubic centimeters; km = kilometers; kWh = kilowatt-hours.

layer. In this nozzle movement process, the laser device and powder feeder would have a pause.

The primary input material of AM system investigated is the metal powder. Currently, many methodologies can be used

for metal powder production, such as molten salt electrolysis, sponge iron process, metallothermic reduction, and atomization. Owing to the high productivity and powder quality, atomization is the most commonly utilized technology (Burkhart and Aurich 2015). In the atomization process, the titanium alloy is heated until reaching its melting point in the crucible. Then, the drop flow of metallic fluid is disintegrated by high-speed inert gas (argon) and congealed during its flight and fall down as metal powder. The SEC with regard to atomization process is studied by many researchers and range from 0.27 kilowatt-hours per kilogram (kWh/kg) to 0.65 kWh/kg (Serres et al. 2011). Relevant data about 1 kg of powder production in atomization process is listed in table 2.

The impeller studied can be decomposed into two parts: an entity of circular truncated curve cone (substrate) and eight blades. The former one is produced by precision casting and blades are cladded on this entity by AM to form a rough impeller. Subsequently, the rough impeller should go through a series of aftertreatment like precision milling and heat treatment. Aforementioned, AM is widely recognized as an efficient way for complicated or difficult-to-machine components production. Considering the complex geometry of blades and the simple shape of substrate, those two parts are fabricated in separately manufacturing methods in which substrate is produced by CM and blades by AM. Therefore, in this section, the impeller is actually produced by AM in combination with CM, which, for the ease of reading, is also abbreviated as AM. Energy consumption of the substrate and aftertreatment are determined by multiplying the mass with relevant SEC. Casting SEC of foundry and finish machining SEC in aftertreatment are 1.87 MJ/kg and 600 MJ/kg, respectively (Yoon et al. 2014; Gutowski et al. 2009). Data on workblank of the substrate as well as the removed material in aftertreatment processes are determined by the CAD model. Additionally, energy for the blades manufacturing is roughly calculated by multiplying the working time with relevant rated power of the six units in laser cladding system as depicted earlier. Energy data obtained in this manner are not quite accurate since the power of the equipment fluctuates during the working time, but the rough data in this study are also representative to reflect the energy consumption in LCA cases (Shi et al. 2015). The nethermost side of table 2 presented the summary of energy consumption related to AM.

### Additive Remanufacturing for Impeller

RM is the process as restoring the degraded component to the original working performance at least not worse than the newly manufactured equivalency. Thus, the residual value of the extraction and refined materials or processes can be retained (Ijomah et al. 2007). Some typical procedures in RM include disassembly, cleaning, inspection/sorting, RM restoration, testing, reassembly, and package. Impellers are generally expensive components, which makes it not cost-effective to manufacture a new one. However, impellers RM would effectively extend the life cycle of the waste impellers and the performance specifications of the remanufactured impeller are at least equal to that of

the newly manufactured impeller. Through the utilization and recovery of end-of-life (EoL) parts, RM greatly improves the eco-efficiency and gains many economic and environmental benefits. RM is a good alternative for waste management strategy and has much better environmental performance compared with recycling and landfilling (Zanghelini et al. 2014). Comparative environmental impact assessments between manufacturing and RM have been conducted on many devices such as engines, manual transmission, refrigeration, and air-conditioning compressors (Biswas and Rosano 2011; Liu et al. 2014; Warsen et al. 2011; Zanghelini et al. 2014). Laser cladding is a common technology in the RM field and it uses waste components as workblank to restore their original sizes and shapes. The performance and quality of remanufactured parts through laser cladding are even better than the initial ones (Luo et al. 2016; Liu et al. 2014).

The blades of the investigated impeller are prone to fracturing during operation due to fatigue and abrasion, design errors, production flaws, and operation outside of design parameters. Laser cladding is a specific method used in the remanufacturing industry to repair fractured blades of impellers (presented in figure S1 in the supporting information available on the Journal's website). In the present study, we suppose the impeller has four fractured blades and 2.5 cm<sup>3</sup> defect on average for each blade. Based on the principle of 3D reverse measuring, precision 3D scanner is used to understand the shape and size of the fractured section, which would help to accurately control the dimension and appropriately select technical parameters. Generally, the surfaces of waste impellers are covered with foulings that are removed by two cleaning periods including high-temperature decomposition and liquid blasting. The former period aims at getting rid of contaminates while the latter one cleans the metal particle on the surface. Before the laser cladding, pretreatment of the fracture section should be conducted firstly. 0.8 kg diesel and 0.54 kWh electricity are consumed in these remanufacturing cleaning processes. Based on the field research, the pretreatment processes are comprised of three parts: obtuse angle grooving (120°), oxidation film elimination by abrasive paper, cleaning by acetone (10 g) and ethanol (15 grams [g]). Subsequently, the fractured sections are restored by laser cladding in which 45 g of alloy powder and 2.6 kWh of electricity are consumed. After the cladding, the remanufactured impeller gains its original dimensional precision through accurate grinding and testing, which utilize 1.5 kWh and 0.046 kWh of electricity, respectively.

### Life Cycle Assessment

LCA is a scientific comparative assessment and analysis of a process, service, or product system. Its distinctive and intrinsic features such as "functional unit" and "problem-shift avoidance" distinguish itself from the other environmental assessment methodologies and allow quantification and comparison of the accumulative environmental impacts involved in fulfilling specific or similar purpose (Klöpffer 2014; US EPA 2006). This science-based approach can greatly help for supporting

business decisions and making modern environmental policies with respect to sustainable consumption and production. According to the framework of LCA defined by the International Organization for Standardization (ISO) 14040 and 14044, LCA consists of the following four phases:

- (a) Goal and scope definition: defines the purpose and approach of integrating the life cycle environmental impacts into decision making, conduct functional unit definition, and the system boundary division.
- (b) Life cycle inventory analysis (LCI): quantifies the energy and raw materials consumption as well as atmospheric emissions, effluents, solid wastes, and other emissions all along in the life cycle of a process or product.
- (c) Life cycle impact assessment (LCIA): Inputs and outputs of elementary flows as identified in LCI are converted into impact indicators whose results pertain to potential human health risk, ecological disruption, and resource depletion.
- (d) Interpretation: Results of LCI and LCIA are identified and checked collectively and are analyzed in terms of completeness, accuracy, and assumptions throughout the LCA study.

### Goal and Scope Definition

The objective of this study is to quantify and compare the consumed energy, released emissions, and environmental impacts of conventional manufactured impeller, additive manufactured impeller, and the additive remanufacturing counterpart. This LCA method would comprehensively support environmental sustainable impeller production and help decision makers have a comparable selection. The results of this study would provide possible improvement for sustainable impeller production. In order to compare the environmental loads of the impeller production processes through these manufacturing approaches, the functional unit of this study is defined as “manufacturing a specific titanium alloy impeller.”

In this comparative LCA study, the CM, AM, and RM share the same aftertreatment, usage, and EoL disposal. Thus, those processes or stages are removed out of the system boundary. As shown in figure 3, the cradle-to-gate system boundary starts from raw materials extraction to complete the impeller production. Owing to the systematic complexity, this figure represents simplified system boundaries of those three manufacturing methods for impeller production. Processes or flows presented with dashed lines are not considered in this study.

In the CM system, not only the impeller is produced, but also the by-product (metal chips) is generated. The environmental credits, or environmental benefit, of the waste metal transported and remelted in a nearby iron and steel plant are taken into account. Equipment selected for remelting is a GW-1T furnace and the electricity consumption for 1 tonne (t) of steel (alloy) is about 600 kWh (Li et al. 2013), while the waste metal powder in an AM system is landfilled in the vicinity. In addition, the metal chips of precision grinding in the RM

phase is negligible since a modicum of metal powder consumed to restore fractured blades means an even smaller amount of chips.

Because of the limitation of data procurement when establishing an LCI model, two simplifications are made as follows: (1) All the vehicles related to transportation in this study are trucks, and the carrying capacity is 2 t, consuming gasoline only; and (2) transportation distance during the reverse logistics of waste impeller is supposed to be 400 km, on average, due to the high uncertainty of service locations.

Raw materials extracted and refined from minerals went through transportation, various manufacturing, etc., and then formed a component. All the data involved in its life cycle are quite numerous and can be classified into two categories: foreground data and background data. Foreground data, referring to the data of primary concern, are directly related to the impeller manufacturing processes. The prime data of these manufacturing methods are presented in the section *Impeller Manufacturing Methods and Data*. Energy consumed in CM is mainly determined according to the principles and theories of cutting, while the amount of materials and energy in AM is estimated with the combination of laser cladding forming in the laboratory. The data about RM are mainly obtained from RM practices. Additionally, in these manufacturing processes, accessory materials are also consumed, such as CLF and metal powder. Data about their production process are collected through literature review. Background data, such as raw material extraction, beneficiation, transportation, electricity, and argon, etc., are gained from the Chinese Life Cycle Database (CLCD) developed by Sichuan University. Data of CLCD are from factories, statistics, technical literature, and the China Pollution Source Census, which represent the average technology in the Chinese market.

### Life Cycle Inventory Analysis

The inputs of these three manufacturing systems are simply electricity, powder or workblank, and some accessories. However, both the CM and AM have by-products (metal chips). Thus, there is an allocation issue between the original manufacturing system and the RM system.

Allocation, also called “partition,” is almost an inevitable issue encountered in LCA practices. To solve the multifunctionality of processes, the ISO 14044 indicates a hierarchy of approaches to this problem. The first approach is to subdivide the multifunctional unit processes, generally regarded as a black box, to monofunctional single processes, which would help avoid allocation. The second approach is system expansion (encompassing the substitution). System expansion, or “system enlargement,” means to add other specific processes or functions to make two systems comparable, while the substitution, also called “system reduction”/“crediting,” is to subtract the not required functions and their related LCI from the analyzed system. It is a special method of applying the system expansion principle. The third approach is partition or allocation. According to the allocation criteria, such as mass, energy, marker

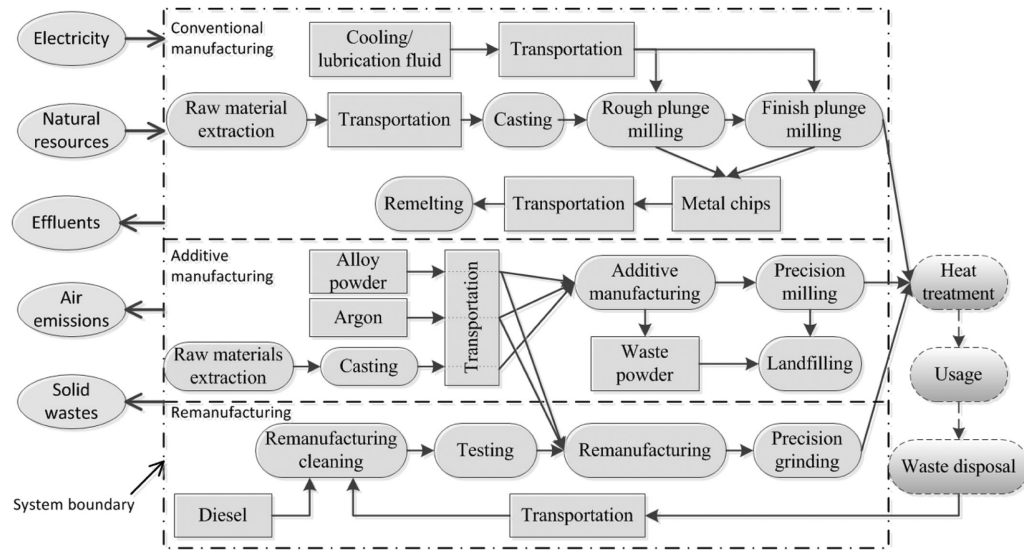

**Figure 3** Simplified life cycles of conventional manufacturing, additive manufacturing, and remanufacturing for the impeller, indicating the system boundary.

price, element content, and molar weight, etc., the inputs and outputs are divided to solve the multifunctionality (ISO 2006; IES 2010). Notably, the first approach is not suitable for the allocation between the main product and by-product in the CM and AM since it is unfeasible for these manufacturing processes to be further subdivided. As the last recommendation in ISO hierarchy, the third approach is based on physical causality and reduces the robustness of the results, while the second substitution approach is optimal for dealing with the allocation issue in this study. The environmental credit of the remelted alloy, cited from the CLCD, is taken into account in the LCIs of CM and AM.

Another allocation issue lies in the original manufacturing of impeller (“preconsumer” system) and the remanufacturing of the impeller (“post-consumer” system), a cascade two production systems, forming a typical open-loop recycling. Basically, open-loop recycling occurs where: (1) waste energy or materials related to a product are recycled to a new product system and (2) recycled energy or materials are introduced from one system to another application in cascade use (Li et al. 2013). The Society of Environmental Toxicology and Chemistry (SETAC) once indicated that no scientifically satisfying method exists to separate the subsystems coupled by open-loop recycling and location should be logical and consistent with the goal of the study. We apply the 50:50 rule for the case in this study (allocation between the “preconsumer” system and “postconsumer” system in a ratio of 50:50). More specifically, environmental loads related to the raw material production and transportation as well as the waste disposal and recycling are equally undertaken by both the original manufacturing and RM. This rule can guarantee a relatively fair distribution of environmental loads and is feasible within the LCA framework. It also allows the independent analysis of these two systems and avoids double counting of environmental burdens related to recycling (Klopffer 1996; Shen

et al. 2010; Ekvall and Tillman 1997). In this study, we suppose the waste impeller for RM is produced by CM since the CM is still the mainstream impeller manufacturing method.

According to the processes within the system boundary and the allocation rules aforementioned, the foreground data (data identified in the three manufacturing processes) and background data (the corresponding data in the LCA database) are integrated to compile the LCIs of CM, AM, and RM tabulated in table 3.

For the resources consumption, table 3 denotes that CM contributes the most to coal consumption and RM consumes the least amount of resources. Raw material extraction, beneficiation, metallurgic process, in particular, the manufacturing need a great deal of electricity. The majority of the energy derives from the thermal power plants, which mainly rely on hard coal for electricity generation. Coal combustion combined with incomplete combustion releases notably higher  $\text{CO}_2$ , and life cycle  $\text{CO}_2$  emission of CM is 2.6 times the amount discharged in AM and nearly 7.4 times that of RM. And the coal utilized to generate electricity is generally not purely containing many elements like sulfur, phosphorus, and arsenic. Sulfur dioxide ( $\text{SO}_2$ ), phosphate, and hydrogen chloride (HCL) are emitted even though some desulfuration and HCL control technologies are integrated into the electricity generation process. Besides, CLF is also a noticeable pollution source. Production of CLF, 31.6 L used in CM processes, approximately consumes 115 kWh of electricity, which is an important contributor to these emissions, while electricity consumed in AM processes is mainly from two aspects: powder production and laser cladding forming. Owing to the high efficiency of atomization, it merely requires a small amount of energy. Further, AM possesses high material efficiency since only a few chips and CLF are produced in the final precision milling. By contrast, only a small quantity of powder and energy is consumed to restore the fractured blades



**Table 3** Main resource consumption and emissions in the life cycle of impeller manufacturing methods

Pollution type	Resources/emissions	Conventional manufacturing	Remanufacturing	Additive manufacturing
Resource consumption (kg)	Coal	339.21	41.92	124.01
	Natural gas	0.249	0.081	0.187
	Crude oil	0.890	0.899	0.461
Water emission (kg)	Ammonia nitrogen	1.69E-03	1.09E-03	1.30E-03
	Nitrate	4.98E-05	4.34E-05	8.84E-05
	Phosphate	1.28E-04	1.13E-04	2.31E-04
Atmospheric emission (kg)	CO <sub>2</sub>	520.58	70.52	197.88
	CH <sub>4</sub>	1.495	0.212	0.550
	HCL	0.136	0.012	0.041
	HF	0.017	0.002	0.005
	NO <sub>2</sub>	9.37E-03	5.27E-03	1.11E-02
	SO <sub>2</sub>	1.493	0.162	0.498
	H <sub>2</sub> S	6.50E-03	2.74E-03	6.03E-03
	NO <sub>x</sub>	1.391	0.134	0.435
	Particles PM2.5	1.34E-04	2.64E-04	2.42E-04
	Inhalable particles	4.34E-02	4.24E-02	8.75E-02

Note: kg = kilograms; CO<sub>2</sub> = carbon dioxide; CH<sub>4</sub> = methane; HCL = hydrogen chloride; HF = hydrogen fluoride; NO<sub>2</sub> = nitrogen dioxide; SO<sub>2</sub> = sulfur dioxide; H<sub>2</sub>S = hydrogen sulfide; NO<sub>x</sub> = nitrogen oxides; PM2.5 = particulate matter 2.5 micrometers or less in diameter.

and almost negligible chips and CLF are produced in grinding process in RM.

**Life Cycle Impact Assessment**

LCIA consists of mandatory steps (classification and characterization) and optional steps (normalization and weighting). Resources and emissions are categorized from the LCI into different environmental impact indicators through the classification step. The environmental impact categories selected in the present study are all about the currently most concerned environmental issues in China: global warming potential (GWP); Chinese resource depletion potential (CADP); water eutrophication potential (EP); acidification potential (AP); and respiratory inorganics (RI). In the characterization step, the LCI results are converted into these environmental impact indicators by multiplying the characterization factors with the individual inventories data of the LCI. Characterization factors of CADP, GWP, and RI are consistent with ISCP2010, IPCC2007, and IMPACT2002+, respectively, and that of AP and EP are referred from CML2002. Subsequently, normalization, an optimal step, is to express the impact indicator in a manner that each impact category is comparable by dividing a reference value as indicated in equation (4):

$$N_j = \frac{\sum_i Q_{ji} \times CF_{ji}}{NF_j} \quad (4)$$

where  $N_j$  is the normalization result of environmental indicator  $j$ ,  $Q_{ji}$  is the amount of resource or emission  $i$  classified in indicator  $j$ ,  $CF_{ji}$  is the corresponding characteristic factor of emission  $i$  classified in indicator  $j$ , and  $NF_j$  is the normalization factor of indicator  $j$ .

The reference values are selected based on emissions or resources used for China on per capita. Characterization and normalization factors and the results of the normalization are shown in table 4. It is evident from this that conventional manufacturing has distinctively larger environmental impacts in terms of GWP, AP, CADP, and EP followed by AM and RM. Compared with the CM, RM of the impellers would reduce the GWP, CADP, and EP by 64.7%, 66.1%, and 75.4%, respectively, and eliminate the majority of the emissions related to AP and RI. For the RI, CM still has the largest environmental impact. However, RI of RM is slightly higher than that of AM.

**Interpretation**

Interpretation identifies information from the previous three steps of LCA to find out the environmental hotspot in the life cycle of impeller production. Environmental impacts of CM, RM, and AM are tabulated and compared in table 4. Conventional manufacturing has the predominant environmental impact toward all the selected environmental indicators. Compared with CM, AM exhibits a higher material utilization rate since AM does not generate swarf and the metal powders used in AM can be recycled. This stands in contrast to CM, where a large proportion of material is removed from the workblank, resulting in a considerable waste stream. Further, CM generally requires the parts to be moved frequently between operations during manufacturing, whereas AM is conducted in one location. Additionally, AM exhibits high time and energy efficiency, especially in the production of components with complex surfaces. RM, as expected, has the least environmental impacts because of remarkable material and energy conservation. In order to quantify the contribution of life cycle phases,

**Table 4** Normalization results of three manufacturing methods

Environmental impact indicators	Substances	Characterization		Normalization factors	Conventional manufacturing	Remanufacturing	Additive manufacturing
GWP IPCC2007	CO <sub>2</sub>	1	kg CO <sub>2</sub> -eq	7857.45	7.132E-02	8.975E-03	2.518E-02
	CH <sub>4</sub>	25					
	N <sub>2</sub> O	298					
AP CML2002	Ammonia	1.88	kg SO <sub>2</sub> -eq	27.15	9.698E-02	1.954E-05	4.012E-05
	HCL	0.88					
	HF	1.6					
	H <sub>2</sub> S	1.88					
	NO <sub>2</sub>	0.7					
	SO <sub>2</sub>	1					
	NO <sub>x</sub>	0.7					
CADP ISCP2010	Coal	1	kg ce-eq	11532.61	3.173E-02	3.635E-03	1.075E-02
	Natural gas	12.8					
	Crude oil	26.4					
EP CML2002	Ammonia	0.35	kg NO <sub>3</sub> <sup>-</sup> -eq	0.284	2.770E-03	3.373E-04	6.817E-04
	Nitrogen	0.42					
	Ammonia Nitrogen	0.33					
	Nitrate	0.1					
	Phosphate	1					
RI IMPACT 2002+	Particles PM2.5	1	kg PM2.5-eq	11.935	1.182E-02	2.208E-05	1.962E-05
	Inhalable particles	0.536					
	Ammonia	0.121					
	NO <sub>2</sub>	0.127					
	SO <sub>2</sub>	0.078					

Note: GWP = global warming potential; IPCC = Intergovernmental Panel on Climate Change; AP = acidification potential; EP = eutrophication potential; CADP = Chinese resource depletion potential; ISCP = International Society for Comparative Psychology; RI = respiratory inorganics; CO<sub>2</sub> = carbon dioxide; CH<sub>4</sub> = methane; N<sub>2</sub>O = nitrous oxide; HCL = hydrogen chloride; HF = hydrogen fluoride; H<sub>2</sub>S = hydrogen sulfide; NO<sub>2</sub> = nitrogen dioxide; SO<sub>2</sub> = sulfur dioxide; NO<sub>x</sub> = nitrogen oxides; PM2.5 = particulate matter 2.5 micrometers or less in diameter; kg = kilograms; eq = equivalent; ce= carbon dioxide emission; NO<sub>3</sub><sup>-</sup> = inorganic nitrate.

a contribution analysis is conducted for each impeller manufacturing method. For CM, RM, and AM, the environmental impact of different processes are presented in figure 4 (detailed numerical comparison is shown in table S1 in the supporting information on the Web) indicating their relative magnitudes in terms of each environmental indicator.

With respect to AM, aftertreatment includes the final precision milling and the disposal of chips in which not much emissions are generated. However, the substrate production is more responsible for environmental impact loads as shown in figure 4a because of its larger mass and the high energy consumption and emissions, which also rightly demonstrates that AM for the blades of the impeller has less environmental impacts compared with its substrate production. In RM, the pretreatment, including cleaning and testing, is the main contributor of AP. It can be seen from figure 4b that the transportation and pretreatment are the predominant factors for EP and RI, respectively. Because diesel combustion emits substantial ammonia and nitric oxide, while the production of materials used in pretreatment phase tends to generate a lot of particles. Approximately 50% of GWP is brought by laser cladding forming, which is also the

main contributor of CADP since the large quantities of powder and electricity required for this process release a great deal of GHGs such as CO<sub>2</sub> and methane (CH<sub>4</sub>). It is evident from figure 4c that machining in CM contributes the largest to GWP, AP, and CADP since it has a large amount of energy consumption. And electricity generation in China mainly relies on coal combustion, which itself is an intense pollution process, while the materials production process brings more in terms of EP and RI because metal production is also an energy-intensive and high-pollution phase including beneficiation and smelting, etc. In order to decrease a specific environmental impact, taking measures on the most influential life cycle stages or processes would drop the environmental loads conspicuously.

### Implications for Additive Manufacturing

As has been stated in table 4, impeller manufactured by AM is environmentally favorable compared with that of CM. AM enables the design flexibility and is suitable for manufacturing the components with complicated surfaces. Many constraints that frequently happen in CM for complex shaped parts include

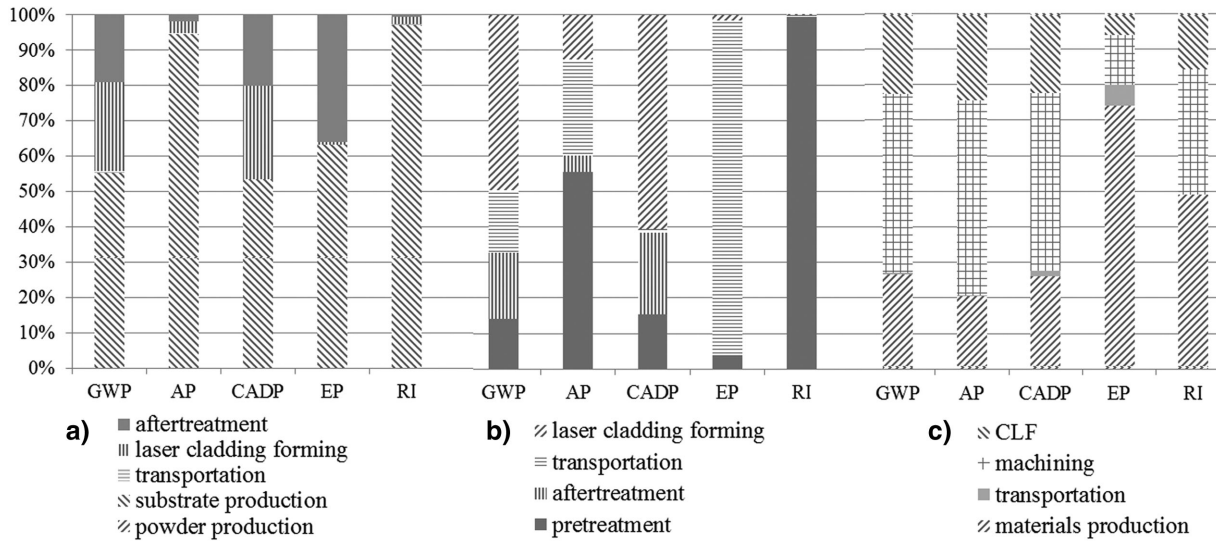

**Figure 4** Environmental impact of each process in (a) AM, (b) RM, and (c) CM. AM = additive manufacturing; AP = acidification potential; CADP = Chinese resource depletion potential; CLF = cooling/lubrication fluid; CM = conventional manufacturing; EP = eutrophication potential; GWP = global warming potential; RI = respiratory inorganics; RM = remanufacturing.

various fixtures, multifarious of tools, possible collision, invisible zones, and difficulty of cutter reaching (Gao et al. 2015). Those manufacturing limitations make CM become not time- and cost-efficient to manufacture complex shape parts. The AM aforementioned is actually hybrid additive subtractive manufacturing, in which only the blades of impeller with a complicated shape are produced by laser cladding forming while the substrate is by turning and milling. However, AM is not always environmentally friendly, in particular when manufacturing parts are with large size and a simple surface. In this section, we defined pure AM as manufacturing the impeller, both blades and substrate, completely by laser cladding forming. Applying the same method presented in the previous section to determine the environmental impacts of pure AM of the entire impeller and to compare with that of CM is shown in figure 5 (detailed numerical values are presented in table S2 in the supporting information on the Web). Notably, different from hybrid additive subtractive production, the environmental impacts of pure AM for the whole impeller have about twice that of CM.

The predominant input material in AM is the powder. The usage efficiency of powder needs further promotion since AM is quite a powder-consuming process particularly in manufacturing of large-size products. The sensitivity analysis indicates that, if the powder usage rate increases 10% in this case, normalization results of GWP and CADP would decrease by about 3.3%. In addition, the increase of the powder usage rate would distinctly save the cost of AM because of the high price of metallic powders. Environmental loads of AM would increase if the size of the component is larger because much more electricity and powder are consumed to build the part. Meanwhile, CM would not be that affected since energy consumption would be similar and environmental impact would just increase slightly (Rajemi et al. 2010). Size and shape are the two important properties of mechanical components. Therefore, AM, CM, and their

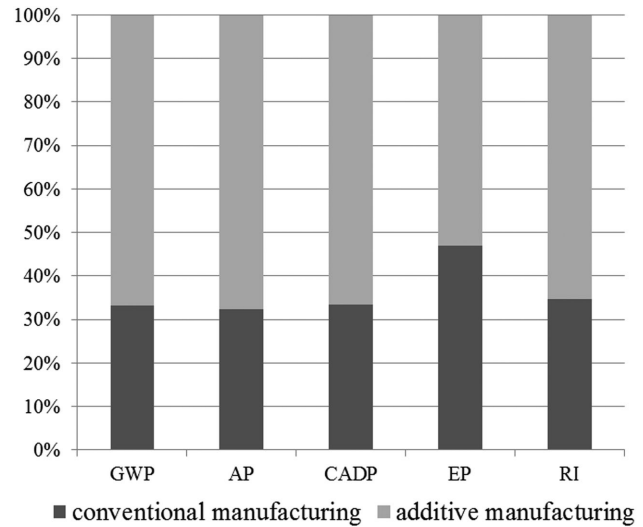

**Figure 5** Environmental impact comparison between pure AM and CM. AM = additive manufacturing; AP = acidification potential; CADP = Chinese resource depletion potential; CM = conventional manufacturing; EP = eutrophication potential; GWP = global warming potential; RI = respiratory inorganics.

combination should be appropriately selected to support sustainable production on the basis of these two properties.

### Conclusions and Perspectives

This article developed a comparative LCA for impeller production by CM, AM (pure AM and hybrid additive subtractive manufacturing), and RM. As for the impeller case in the present study, additive RM has the best environmental performance, followed by AM and CM. However, if the impeller is

produced by pure AM, it would have the largest environmental burden because of the large amount of electricity and powder consumption. According to the contribution analysis, the first priority of CM is to drop energy utilization by optimizing the processing route and choosing rational cutting parameters. RM is widely recognized as an environmentally friendly recycling technology. However, its primary concern is not about further reduction of environmental load, but warranty for the quality of remanufactured products. With respect to AM, the main contribution of environmental impacts is from substrate production. Thus, precision casting or forging for the substrate of impellers would be a great opportunity to decrease life cycle energy consumption and emissions.

It is notable that impellers manufactured by CM, RM, and AM would have different technical characteristics or mechanical properties, which would directly influence their service lives. Through the literature review, we found that almost all the previous studies associated with comparison of manufacturing methods are conducted under the hidden assumption that manufactured products with different methods possess the same mechanical behaviors. This assumption is also made in the present study. Actually, a comprehensive technical evaluation of products to represent the mechanical properties by only one parameter is a big challenge and how to integrate the technical evaluation results into environmental impact assessment is another issue, which should be explored in future work. The scope of this study is confined to the simplest situation and does not consider the transformative potential to substitute existing parts, the impacts toward supply chain, and potential hazards. The redesign of one component to replace many other components by AM would reduce relevant hardware and indirectly reduce environmental impacts. Through waste elimination and just-in-time manufacturing, AM can significantly improve the efficiency of the supply chain to reduce material distribution. The arc light may cause eye irritation and the powder may accidentally spill on skin or trigger respiratory problems. Those impacts are not considered in this environmental impact assessment.

Every AM technology has its own specific application areas and may cause various environmental impacts. And the study from Huang and colleagues shows that energy consumption rate for the same AM process has significant variation (Huang et al. 2013). The energy consumption rates (i.e., kWh of electricity consumed by per kg of parts produced) of some typical AM technologies, such as selective laser sintering, selective laser melting, fused deposition modeling, and stereolithography, had been explored by many researchers (Baumers et al. 2010, 2011, 2013; Luo et al. 1999; Sreenivasan and Bourell 2009); the energy consumption rates of different AM processes with various materials and equipment range from 14.5 kWh/kg to 346.4 kWh/kg. Therefore, it is necessary to investigate the uncertainties affecting the energy use in order to obtain relative accurate environmental assessment results. Additionally, AM has the potential to revolutionize the landscape of supply chain of the manufacturing system, which would significantly reduce logistics cost. However, AM equipment investment is

quite costly; and life cycle cost assessment is also necessary to explore whether AM is cost-effective. AM is still constantly developing and evolving; its environmental impact and cost assessment will still be subjects of great concern in order to support sustainable production.

## Funding Information

The authors gratefully acknowledge the support from the National Basic Research Program of China (Grant No.: 2011CB013406).

## References

- Baumers, M., C. Tuck, D. Bourell, R. Sreenivasan, and R. Hague. 2011. Sustainability of additive manufacturing: Measuring the energy consumption of the laser sintering process. *Proceedings of the Institution of Mechanical Engineers Part B: Journal of Engineering Manufacture* 225(12): 2228–2239.
- Baumers, M., C. Tuck, R. Hague, I. Ashcroft, and R. Wildman. 2010. A comparative study of metallic additive manufacturing power consumption. In *Proceedings of the 2010 Solid Freeform Fabrication Symposium*, 9–11 August, The University of Texas at Austin, Austin, TX, USA.
- Baumers, M., C. Tuck, R. Wildman, I. Ashcroft, E. Rosamond, and R. Hague. 2013. Transparency built-in: Energy consumption and cost estimation for additive manufacturing. *Journal of Industrial Ecology* 17(3): 418–431.
- Bi, G. and A. Gasser. 2011. Restoration of nickel-base turbine blade knife-edges with controlled laser aided additive manufacturing. *Physics Procedia* 12: 402–409.
- Biswas, W. and M. Rosano. 2011. A life cycle greenhouse gas assessment of remanufactured refrigeration and air conditioning compressor. *International Journal of Sustainable Manufacturing* 2(2–3): 222–236.
- Burkhart, M. and J. C. Aurich. 2015. Framework to predict the environmental impact of additive manufacturing in the life cycle of a commercial vehicle. *Procedia CIRP* 29: 408–413.
- Calleja, A., I. Tabernero, J. A. Ealo, F. J. Campa, A. Lamikiz, and L. N. L. de Lacalle. 2014. Feed rate calculation algorithm for the homogeneous material deposition of blisk blades by 5-axis laser cladding. *The International Journal of Advanced Manufacturing Technology* 74(9–12): 1219–1228.
- Chen, J. X. 1994. *Data manual of common diagrams for steel-making*. [Article in Chinese]. Beijing: Metallurgical Industry Press.
- Chuang, L. and H. Young. 2007. Integrated rough machining methodology for centrifugal impeller manufacturing. *The International Journal of Advanced Manufacturing Technology* 34(11–12): 1062–1071.
- Debnath, S., M. M. Reddy, and Q. S. Yi. 2014. Environmental friendly cutting fluids and cooling techniques in machining: A review. *Journal of Cleaner Production* 83: 33–47.
- Ekvall, T. and A. M. Tillman. 1997. Open-loop recycling: Criteria for allocation procedures. *The International Journal of Life Cycle Assessment* 2(3): 155–162.
- Fernández, S., M. Jiménez, J. Porras, L. Romero, M. D. M. Espinosa, and M. Domínguez. 2015. Additive manufacturing and performance of functional hydraulic pump impellers in fused deposition modeling technology. *Journal of Mechanical Design* 138(2): 1–4.

- Frazier, W. E. 2014. Metal additive manufacturing: A review. *Journal of Materials Engineering and Performance* 23(6): 1917–1928.
- Gao, W., Y. Zhang, D. Ramanujan, K. Ramani, Y. Chen, C. B. Williams, C. C. L. Wang, Y. C. Shin, S. Zhang, and P. D. Zavattieri. 2015. The status, challenges, and future of additive manufacturing in engineering. *Computer-Aided Design* 69: 65–89.
- Gibson, I., D. W. Rosen, and B. Stucker. 2015. *Additive manufacturing technologies: 3D printing, rapid prototyping, and direct digital manufacturing*. New York: Springer Science+Business Media.
- Gutowski, T. G., M. S. Branham, J. B. Dahmus, A. J. Jones, A. Thiriez, and D. P. Sekulic. 2009. Thermodynamic analysis of resources used in manufacturing processes. *Environmental Science & Technology* 43(5): 1584–1590.
- Han, F. Y., D. H. Zhang, M. Luo, and B. H. Wu. 2015. An approach to optimize the tilt angle of indexable table for nonorthogonal four-axis milling of impeller. *The International Journal of Advanced Manufacturing Technology* 76(9–12): 1893–1904.
- Han, F. Y., D. H. Zhang, M. Luo, and B. H. Wu. 2014. Optimal CNC plunge cutter selection and tool path generation for multi-axis roughing free-form surface impeller channel. *The International Journal of Advanced Manufacturing Technology* 71(9–12): 1801–1810.
- Huang, R., M. Riddle, D. Graziano, J. Warren, S. Das, S. Nimbalkar, J. Cresko, and E. Masanet. 2015. Energy and emissions saving potential of additive manufacturing: The case of lightweight aircraft components. *Journal of Cleaner Production* 135: 1559–1570.
- Huang, S. H., P. Liu, A. Mokasdar, and L. Hou. 2013. Additive manufacturing and its societal impact: A literature review. *The International Journal of Advanced Manufacturing Technology* 67(5–8): 1191–1203.
- IEA (International Energy Agency). 2015. *CO<sub>2</sub> emissions from fuel combustion—Highlights*. Paris: IEA, Organisation for Economic Cooperation and Development.
- IES (Institute for Environment and Sustainability). 2010. *ILCD handbook: General guide for life cycle assessment—Detail guidance*. Luxembourg: European Commission.
- Ijomah, W. L., C. A. McMahon, G. P. Hammond, and S. T. Newman. 2007. Development of design for remanufacturing guidelines to support sustainable manufacturing. *Robotics and Computer-Integrated Manufacturing* 23(6): 712–719.
- ISO (International Organization for Standardization). 2006. ISO 14044 International Standard. *Environmental management—Life cycle assessment—Requirements and guidelines*. Geneva, Switzerland: International Organization for Standardization.
- Jiang, Z., F. Zhou, H. Zhang, Y. Wang, and J. W. Sutherland. 2015. Optimization of machining parameters considering minimum cutting fluid consumption. *Journal of Cleaner Production* 108: 183–191.
- Klöppfer, W. 1996. Allocation rule for open-loop in life cycle assessment—A review. *The International Journal of Life Cycle Assessment* 1(1): 27–31.
- Klöppfer, W. 2014. Introducing life cycle assessment and its presentation in ‘LCA Compendium’. In *Background and future prospects in life cycle assessment*, edited by W. Klöppfer and M. A. Curran. Dordrecht, the Netherlands: Springer.
- Le Bourhis, F., O. Kerbrat, L. Dembinski, J. Hascoet, and P. Mognol. 2014. Predictive model for environmental assessment in additive manufacturing process. *Procedia CIRP* 15: 26–31.
- Li, T., L. L. Kong, H. C. Zhang, and I. Asif. 2014. Recent research and development of typical cutting machine tool’s energy consumption model. [Article in Chinese]. *Journal of Mechanical Engineering* 50(7): 102–111.
- Li, T., Z. Liu, H. Zhang, and Q. Jiang. 2013. Environmental emissions and energy consumptions assessment of a diesel engine from the life cycle perspective. *Journal of Cleaner Production* 53: 7–12.
- Liu, N., Y. F. Zhang, and W. F. Lu. 2015. A hybrid approach to energy consumption modelling based on cutting power: A milling case. *Journal of Cleaner Production* 104: 264–272.
- Liu, X., X. Meng, H. Liu, G. Shi, S. Wu, C. Sun, M. Wang, and L. Qi. 2014. Development and characterization of laser clad high temperature self-lubricating wear resistant composite coatings on Ti-6Al-4V alloy. *Materials & Design* 55: 404–409.
- Liu, Z., T. Li, Q. Jiang, and H. Zhang. 2014. Life cycle assessment-based comparative evaluation of originally manufactured and remanufactured diesel engines. *Journal of Industrial Ecology* 18(4): 567–576.
- Luo, K. Y., X. Jing, J. Sheng, G. F. Sun, Z. Yan, and J. Z. Lu. 2016. Characterization and analyses on micro-hardness, residual stress and microstructure in laser cladding coating of 316L stainless steel subjected to massive LSP treatment. *Journal of Alloys and Compounds* 673: 158–169.
- Luo, Y. C., Z. Ji, C. Ming, and R. Caudill. 1999. Environmental performance analysis of solid freeform fabrication processes. In *Proceedings of the 7th IEEE International Symposium on Electronics and the Environment*, 11–13 May, Danvers, MA, USA.
- Morrow, W. R., H. Qi, I. Kim, J. Mazumder, and S. J. Kerlos. 2007. Environmental aspects of laser-based and conventional tool and die manufacturing. *Journal of Cleaner Production* 15(10): 932–943.
- NDRC (China National Development and Reform Commission) and SEPA (China State Environmental Protection Administration). 2007. The Eleventh Five-year Plan of National Environmental Protection. [www.gov.cn/zw/gk/2007-11/26/content\\_815498.htm](http://www.gov.cn/zw/gk/2007-11/26/content_815498.htm). Accessed 17 November 2015.
- Pusavec, F., P. Krajnik, and J. Kopac. 2010. Transitioning to sustainable production—Part I: Application on machining technologies. *Journal of Cleaner Production* 18(2): 174–184.
- Rajemi, M. F., P. T. Mativenga, and A. Aramcharoen. 2010. Sustainable machining: Selection of optimum turning conditions based on minimum energy considerations. *Journal of Cleaner Production* 18(10–11): 1059–1065.
- Ren, J., B. Liu, C. F. Yao, K. Shi, Y. S. Liang, and Y. F. Luo. 2010. Research on plunge milling process parameters optimization for TC11 titanium alloy. [Article in Chinese]. *Mechanical Science and Technology for Aerospace Engineering* 29(5): 634–637.
- Serres, N., D. Tidu, S. Sankare, and F. Hlawka. 2011. Environmental comparison of MESO-CLAD<sup>®</sup> process and conventional machining implementing life cycle assessment. *Journal of Cleaner Production* 19(9–10): 1117–1124.
- Shen, L., E. Worrell, and M. K. Patel. 2010. Open-loop recycling: A LCA case study of PET bottle-to-fibre recycling. *Resources, Conservation and Recycling* 55(1): 34–52.
- Shi, J., T. Li, S. Peng, Z. Liu, H. Zhang, and Q. Jiang. 2015. Comparative life cycle assessment of remanufactured liquefied natural gas and diesel engines in China. *Journal of Cleaner Production* 101: 129–136.
- Sreenivasan, R. and D. Bourell. 2009. Sustainability study in selective laser sintering—An energy perspective. In *The 20th Solid Freeform Fabrication Symposium*, 3–5 August, University of Texas at Austin, Austin, TX, USA.
- US EPA (U.S. Environmental Protection Agency). 2006. *Life cycle assessment: Principles and practice*. EPA 600/R-06/060. Cincinnati, OH, USA: National Risk Management Research Laboratory.

- Warsen, J., M. Laumer, and W. Momberg. 2011. Comparative life cycle assessment of remanufacturing and new manufacturing of a manual transmission. In Proceedings of the 18th CIRP International Conference on Life Cycle Engineering, Technische Universitat Braunschweig, 2–4 May, Braunschweig, Germany.
- Wilson, J. M., C. Piya, Y. C. Shin, F. Zhao, and K. Ramani. 2014. Remanufacturing of turbine blades by laser direct deposition with its energy and environmental impact analysis. *Journal of Cleaner Production* 80: 170–178.
- Wong, K. V. and A. Hernandez. 2012. A review of additive manufacturing. *ISRN Mechanical Engineering* 2012: 1–10.
- Yan, X. and Y. Fang. 2015. CO<sub>2</sub> emissions and mitigation potential of the Chinese manufacturing industry. *Journal of Cleaner Production* 103: 759–773.
- Yang, S. and Y. F. Zhao. 2015. Additive manufacturing-enabled design theory and methodology: A critical review. *The International Journal of Advanced Manufacturing Technology* 80(1–4): 327–342.
- Young, H. T. and L. C. Chuang. 2003. An integrated machining approach for a centrifugal impeller. *International Journal of Advanced Manufacturing Technology* 21: 556–563.
- Yoon, H., J. Lee, H. Kim, M. Kim, E. Kim, Y. Shin, W. Chu, and S. Ahn. 2014. A comparison of energy consumption in bulk forming, subtractive, and additive processes: Review and case study. *International Journal of Precision Engineering and Manufacturing-Green Technology* 1(3): 261–279.
- Zanghelini, G. M., E. Cherubini, P. Orsi, and S. R. Soares. 2014. Waste management life cycle assessment: The case of a reciprocating air compressor in Brazil. *Journal of Cleaner Production* 70: 164174.
- Zeng, Q. 2012. Tool path planning and simulation in five-axis NC machining of integral impeller. [Article in Chinese]. Master's thesis, Nanjing University of Aeronautics and Astronautics, Nanjing, China.
- Zhang, H. and K. R. Haapala. 2015. Integrating sustainable manufacturing assessment into decision making for a production work cell. *Journal of Cleaner Production* 105: 52–63.
- Zhang, S., J. F. Li, and Y. W. Wang. 2012. Tool life and cutting forces in end milling Inconel 718 under dry and minimum quantity cooling lubrication cutting conditions. *Journal of Cleaner Production* 32: 81–87.
- Zhu, Q., F. Lujia, A. Mayyas, M. A. Omar, Y. Al-Hammadi, and S. Al Saleh. 2015. Production energy optimization using low dynamic programming, a decision support tool for sustainable manufacturing. *Journal of Cleaner Production* 105: 178–183.

### Supporting Information

Supporting information is linked to this article on the *JIE* website:

**Supporting Information S1:** This supporting information contains additional data related to the (1) environmental comparison among different manufacturing processes of each manufacturing method; (2) fracture damage of blades; and (3) general procedures of the investigated manufacturing methods.

Copyright of Journal of Industrial Ecology is the property of Wiley-Blackwell and its content may not be copied or emailed to multiple sites or posted to a listserv without the copyright holder's express written permission. However, users may print, download, or email articles for individual use.